

# AUTO SOLIDS<sup>®</sup> *Express*

## *Feature Summary*

### Key Features

**100% AutoCAD Compatibility**--By running inside of AutoCAD, all AutoSolids data remains in native .dwg format at all times. Existing AutoCAD investments remain fully utilized, and time-consuming conversion processes are completely avoided.

**Constraint-free Parametric Solid Modeling**--AutoSolids' parametric 3D solid modeling system offers greatly improved accuracy over 2D design methods, and is much faster and easier to use than traditional constraint-based solid modeling systems.

**QuickDraw<sup>™</sup>**--AutoSolids' QuickDraw feature automatically creates multiview 2D geometry for fast, accurate 2D drawing production.

**RealView<sup>™</sup>**--AutoSolids' numerous realtime display modes and viewing and visualization tools streamline the 3D design process.

**AutoCAD-standard Interface**--Designed specifically for AutoCAD, AutoSolids is immediately familiar to existing AutoCAD users for immediate productivity. Flexible interface and customization options maximize individual user efficiency.

### COMPATIBILITY

- AutoSolids runs inside of AutoCAD versions 14.01 thru 2008 and all corresponding versions of Mechanical Desktop<sup>®</sup>, AutoCAD Mechanical, and AutoCAD Architectural Desktop<sup>™</sup>.
- Solid models created with AutoSolids and then opened by AutoCAD without AutoSolids are immediately recognized as native AutoCAD solids, and can be used with any of the native AutoCAD solids commands(union, subtract, etc.).
- AutoSolids models can be exported through any of the native AutoCAD export functions(IGES, ACIS, STEP, etc.) with results identical to native AutoCAD solids.
- Existing solids created in AutoCAD or in Mechanical Desktop(with the non-parametric standard AutoCAD solid modeling commands) without AutoSolids are immediately recognized by AutoSolids as solid primitives with no historical data for editing. They can be used in further AutoSolids construction operations, with any such operations being editable by AutoSolids.
- Mechanical Desktop parametric parts are recognized only as proxies by AutoCAD, with or without AutoSolids. Mechanical Desktop parts must first be converted to AutoCAD solids from within Mechanical Desktop before AutoCAD, with or without AutoSolids, will recognize them as solids.



*AutoSolids, QuickDraw, and RealView are trademarks or registered trademarks of AutoSolids, Inc.*

*AutoCAD, Mechanical Desktop, AutoCAD Architectural Desktop, and Autodesk are trademarks or registered trademarks of Autodesk, Inc.*

## SOLID CREATION

### **PRIMITIVE SHAPES**

- Box
- Cylinder
- Extrude
- Revolve
- Sweep
- Cone
- Sphere
- Wedge
- Torus
- Text

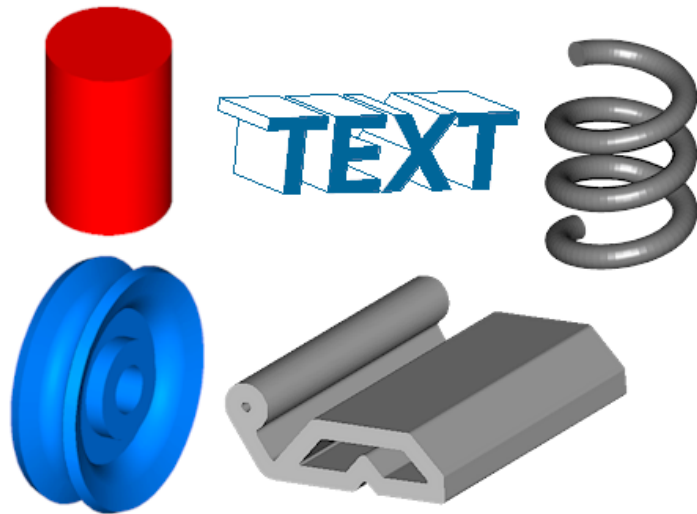

### **PARAMETRIC ARRAYS**

- Polar
- Rectangular

### **PRIMITIVE CREATION, COMMON OPTIONS**

- Option to Preview as parameters are varied
- Option to either “pick” or type any or all parameter values
- Options to Zoom, Pan, Hide, and Regen during creation
- Options to Move, Rotate, and Align the primitive during creation
- Options to perform composite creation commands simultaneously with primitive creation

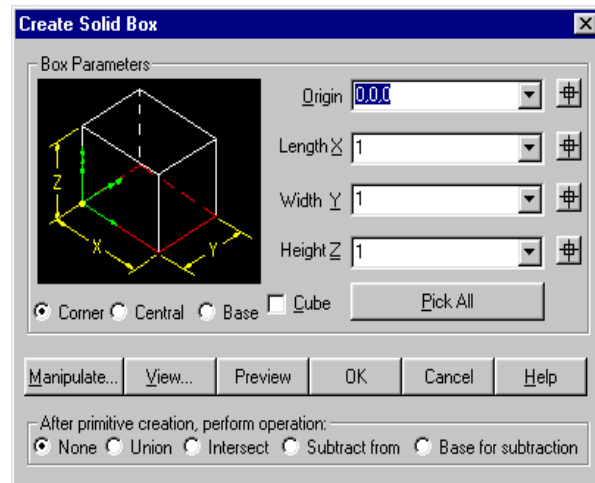

### **COMPOSITE CREATION COMMANDS**

- Union
- Subtract
- Intersect

### **MODIFIER CREATION COMMANDS**

- Fillet
- Chamfer
- Slice

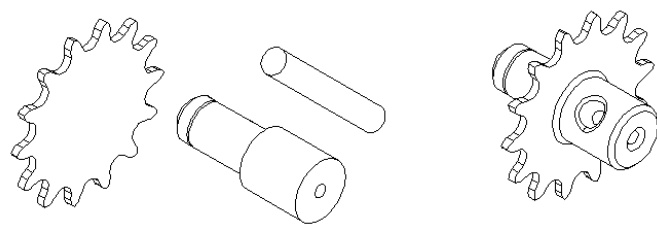

### **QUICKCUT**

- Cuts through single or multiple solids with single or multiple, open or closed 2D profiles.

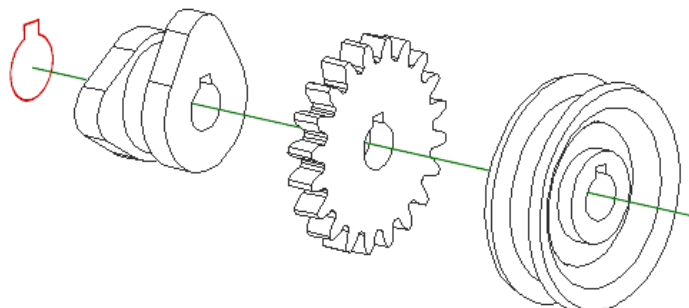

## SOLID EDITING

### PRIMITIVE EDITING

- Any and every parameter(box length, cylinder radius, extrusion taper angle, etc.) can be changed and previewed during or after primitive creation.
- Primitive Styles(i.e. Corner, Central, Base) can be changed during or after creation without relocating the primitive.
- Profiles and Paths can be copied, stretched, or replaced with entirely new entities.
- Any or all primitive modifications can be Undone prior to committing changes.

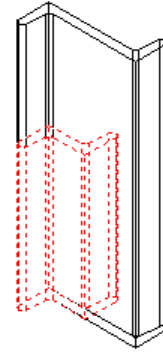
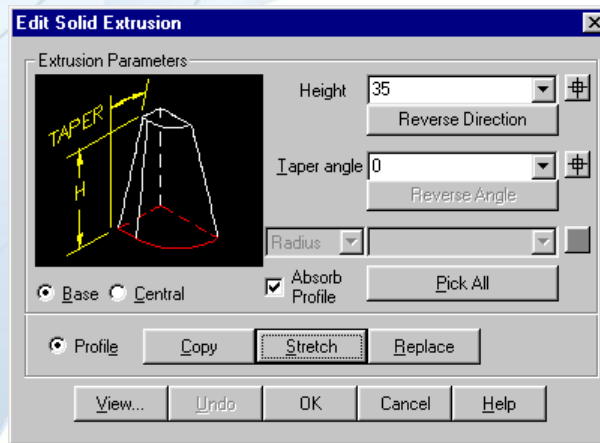

### COMPOSITE EDITING

- Composite operations(union, subtract, intersect) can be retracted, one step at a time, to return any or all of the original primitives, which can then be edited and recombined back into the composite.
- All composite commands can be retracted in a single step to immediately yield a complete set of primitives from the composite.

### MODIFIER EDITING

- Single or multiple fillets or chamfers can be deleted.
- Single or multiple slices can be deleted.

### COMMON EDITING FEATURES(PRIMITIVES, COMPOSITES, OR MODIFIERS)

- Standard AutoCAD commands can be used to move, copy, rotate, scale, erase, mirror, align, or array primitives or composites.
- Standard AutoCAD commands can be used to change the color, layer, or linetype of primitives or composites.
- Zooms, Pans, Hides, and Regens can be performed during editing.

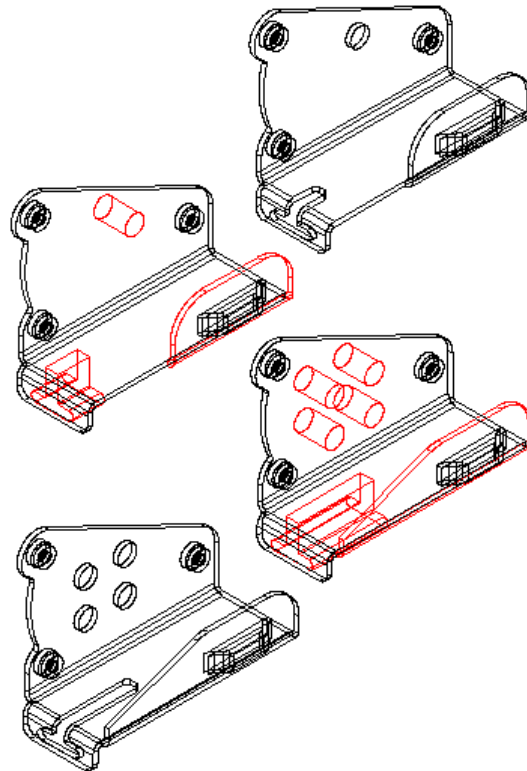

## QUICKDRAW

- Instantly creates 2D drawing geometry from single or multiple solids for up to 6 orthographic and 4 isometric views
- Inclusion or exclusion of visible and hidden lines
- Inclusion or exclusion of tangent edges
- Color, layer, and linetype controls for both visible and hidden lines
- Orientation of all views by WCS, UCS, or current View

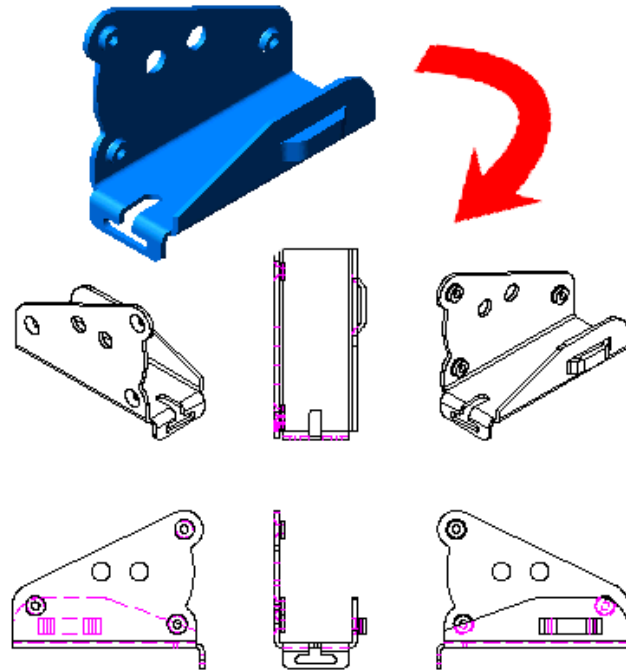
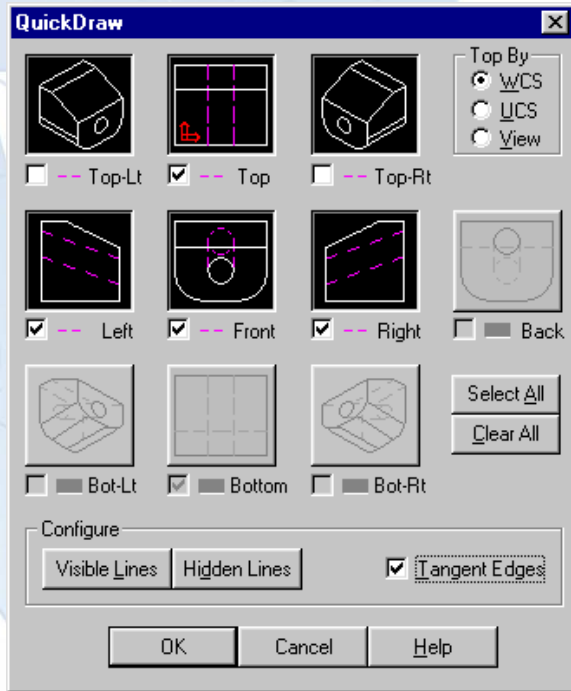

## VISUALIZATION

- RealView real-time viewing modes include:
  - Wireframe without silhouette edges
  - Wireframe with silhouette edges
  - Hidden lines removed
  - Shaded with all wireframe edges visible
  - Shaded with hidden wireframe edges removed
  - Shaded with all wireframe edges removed
- RealView real-time viewpoint manipulation controls include:
  - Zoom
  - Pan
  - Rotation about aggregate center of geometry
  - Rotation about user-specified center point
  - Continuous rotation about aggregate center of geometry
  - Continuous rotation about user-specified center point
- Solids are continuously previewed in the graphics window while being created or changed.
- All major AutoCAD visualization tools(materials, lights, etc.) and their related commands, settings, and variables are easily accessed through the 3D Command Center Visualization Page.

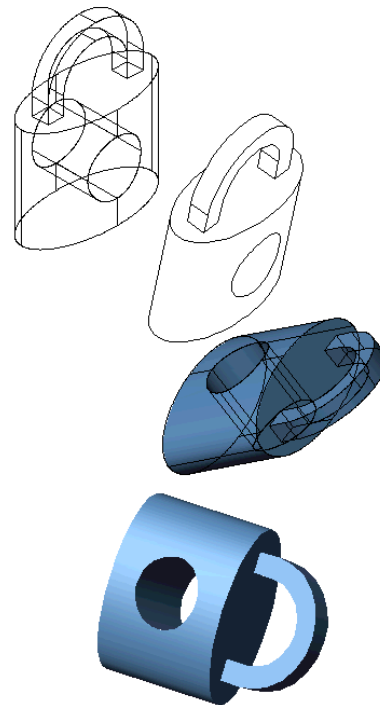

## INTERFACE

- The 3D Command Center™ provides quick access not only to the commands introduced by AutoSolids, but all major 3D commands within AutoCAD, organized in a single pop-up dialog with 5 pages:
  - Solids Page
  - UCS Page
  - View Page
  - Visualization Page
  - Setup Page
- Toolbar and Pull down menu options of all AutoSolids commands are available.
- All AutoSolids commands follow AutoCAD-standard syntax and nomenclature.
- The majority of commands have both dialog-driven and command-line-driven interaction, selectable by the user on a global or command-by-command basis.
- Primitive creation and editing dialogs contain simple yet complete graphical depictions of every defined parameter.
- Radial parameter values can be specified either by Radius or Diameter interchangeably.
- Numeric parameter values can be specified by typing, entering mathematical expressions, or by graphical picks.
- AutoSolids automatically loads whenever AutoCAD starts.
- A single installation of AutoSolids can be used with multiple AutoCAD profiles, each maintaining different interface options.

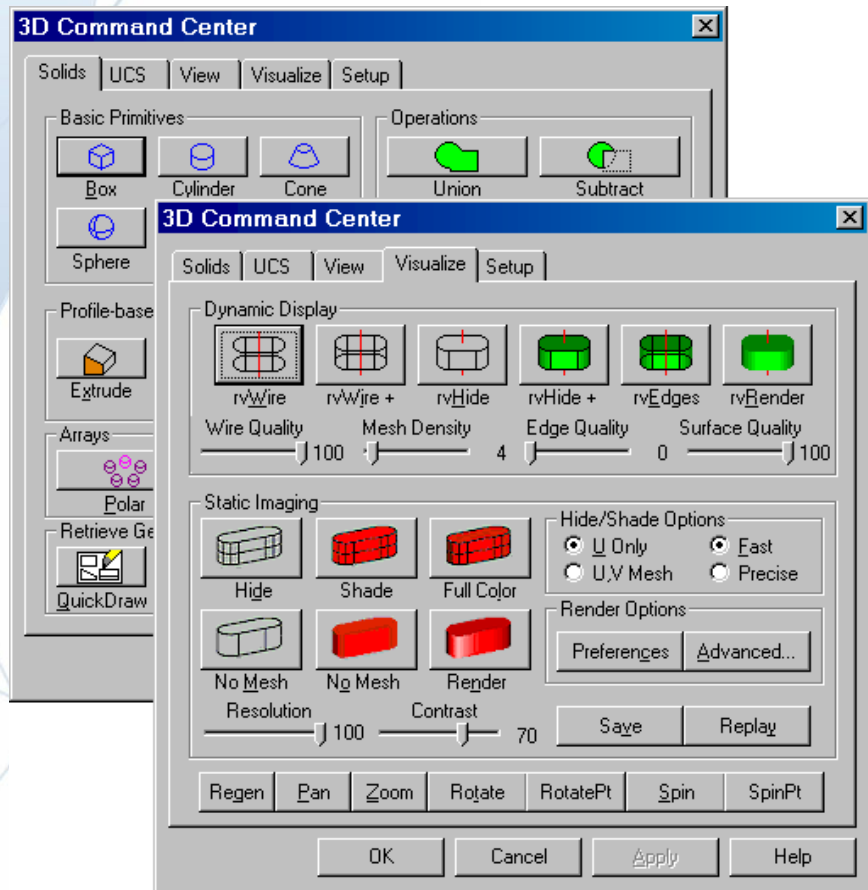

## UTILITIES AND MISCELLANEOUS FEATURES

- Individual faces and edges can be extracted from solids.
- Solids can be exploded into faces or wireframe elements.
- All historical data can be purged from any solid, reducing file size and preventing editing capabilities.
- 2D cross sections can be cut through any plane on any solid.
- Multiple solids can be checked for interference with each other.
- Mass properties can be retrieved from any solid.
- Construction information for any solid can be listed in either detailed or short form.
- UCS enhancements include defining by face and the ability to scroll through either the “recently used UCSs” list or the “saved UCSs” list.
- Viewing enhancements include the ability to scroll through either the “recently used Viewpoints” list or the “saved Viewpoints” list.